



Università
della
Svizzera
italiana

Software Institute



ASE 2021

DEEPMETIS: AUGMENTING A DEEP LEARNING TEST SET TO INCREASE ITS MUTATION SCORE



VINCENZO
RICCIO

 @p1ndsvin



NARGIZ
HUMBATOVA

 @nargiz_hmbtv



GUNEL
JAHANGIROVA

 @guneli_j



PAOLO
TONELLA

 @paolo_tonella

MUTATION TESTING

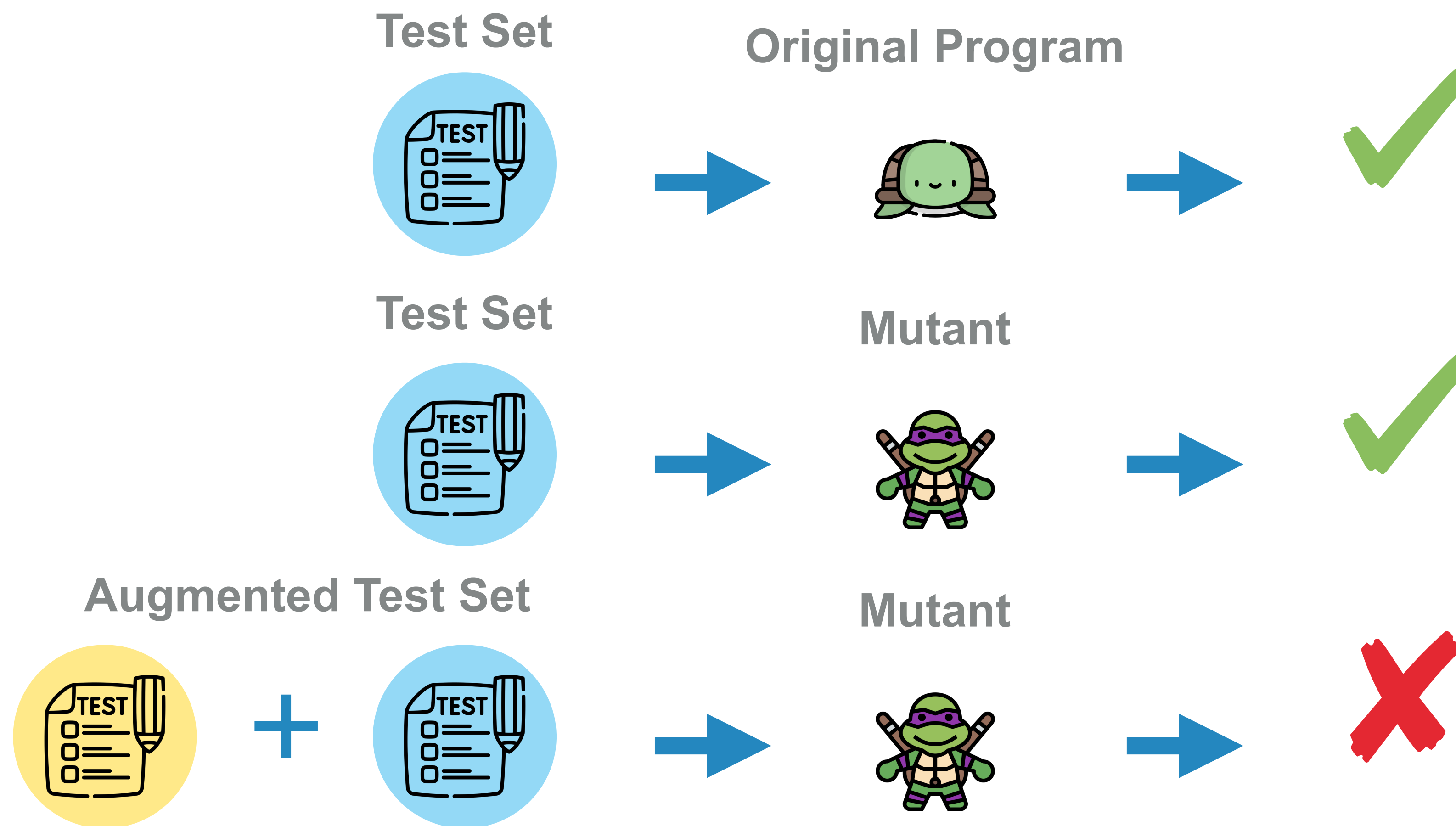

TRADITIONAL SOFTWARE MUTANTS

Original Program

```
public int calc(int x, int y){  
    int z = x + y;  
    return z % 3;  
}
```

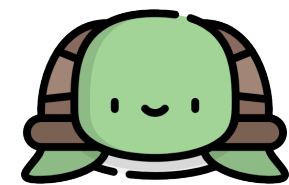

Mutant

```
public int calc(int x, int y){  
    int z = x + y;  
    return z + 3;  
}
```



DL FAULT INJECTION WITH DEEPCRIME



Training Data

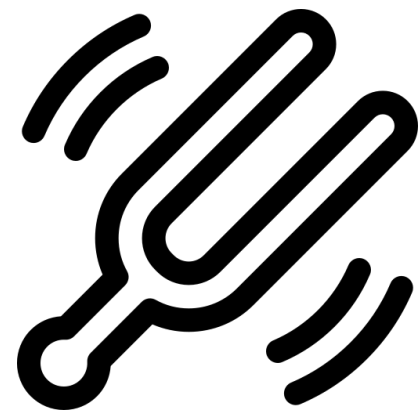

Hyperparameters

+

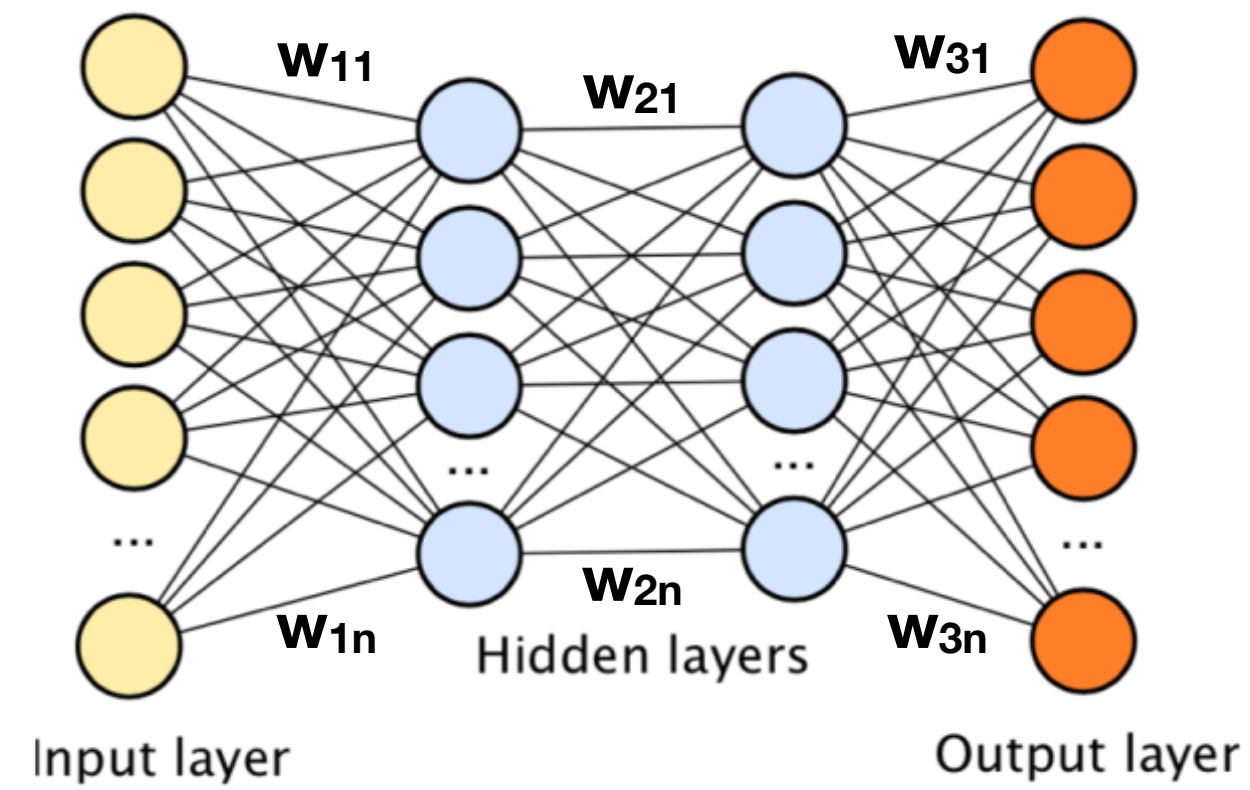

Model Architecture

Train



Original Model

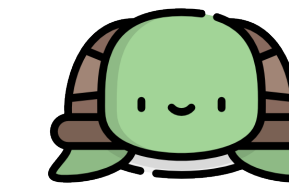

DL FAULT INJECTION WITH DEEPCRIME

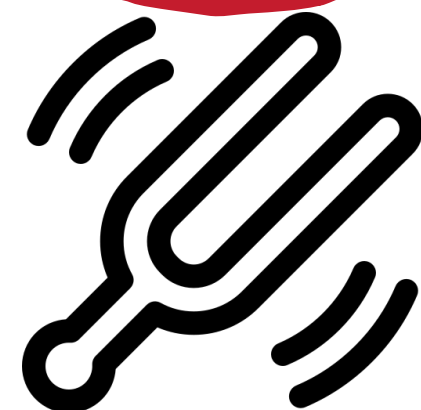

Hyperparameters

+

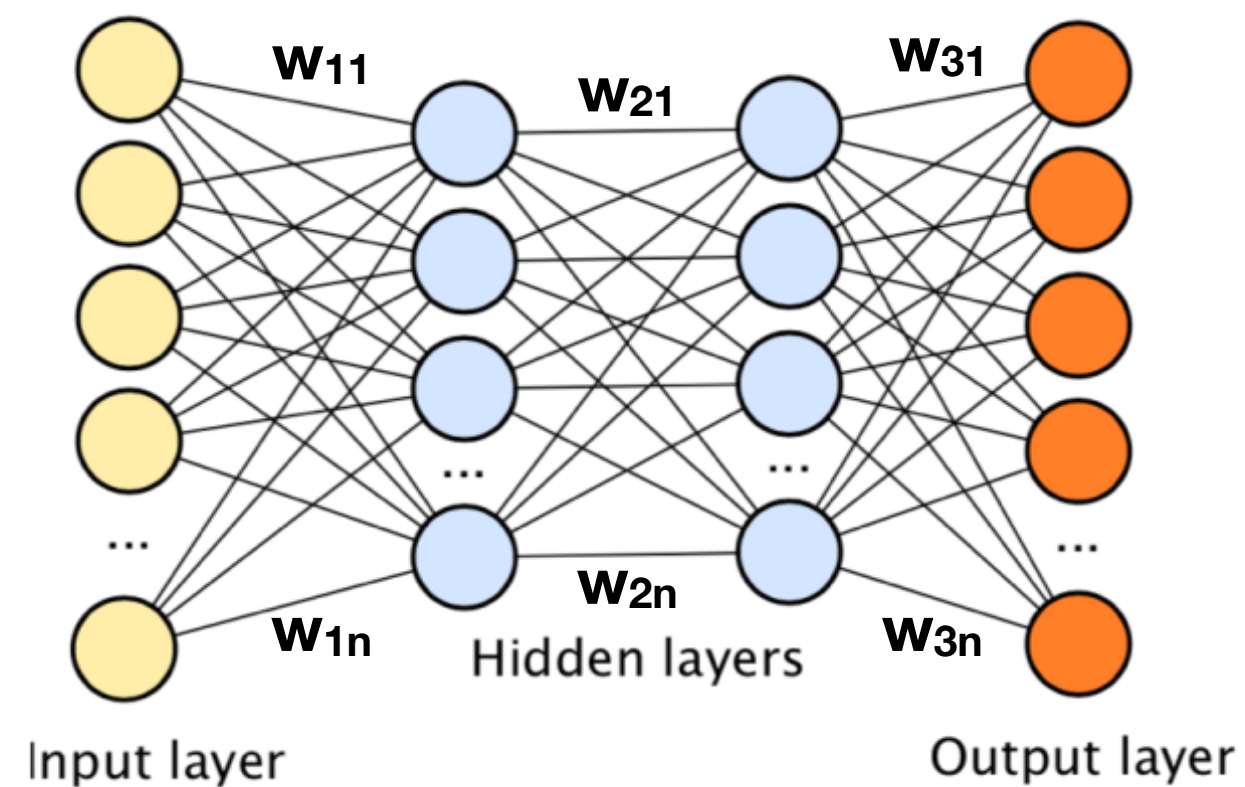

Model Architecture



Mutant Model



DeepCrime: Mutation Testing of Deep Learning Systems Based on Real Faults

Nargiz Humatova
nargiz.humatova@usi.ch
Università della Svizzera italiana (USI)
Lugano, Switzerland

Gunel Jahangirova
gunel.jahangirova@usi.ch
Università della Svizzera italiana (USI)
Lugano, Switzerland

Paolo Tonella
paolo.tonella@usi.ch
Università della Svizzera italiana (USI)
Lugano, Switzerland



ISSTA 2021

STATISTICAL MUTATION KILLING

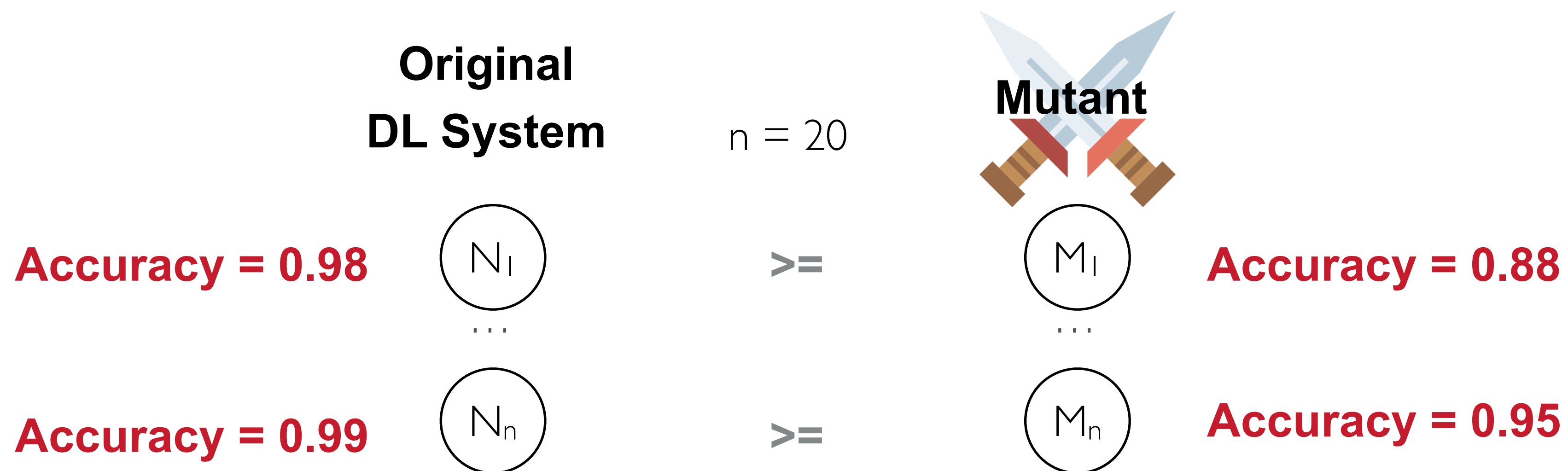

2020 IEEE 13th International Conference on Software Testing, Validation and Verification (ICST)

An Empirical Evaluation of Mutation Operators for Deep Learning Systems

Gunel Jahangirova, Paolo Tonella
{gunel.jahangirova, paolo.tonella}@usi.ch
Software Institute - Università della Svizzera italiana, Lugano, Switzerland

ICST 2020

“A mutant is **killed** if the difference of the performance measurements across **n** re-trainings of the mutant and the original model are **statistically significant**”



GOAL

WEAK TEST SET

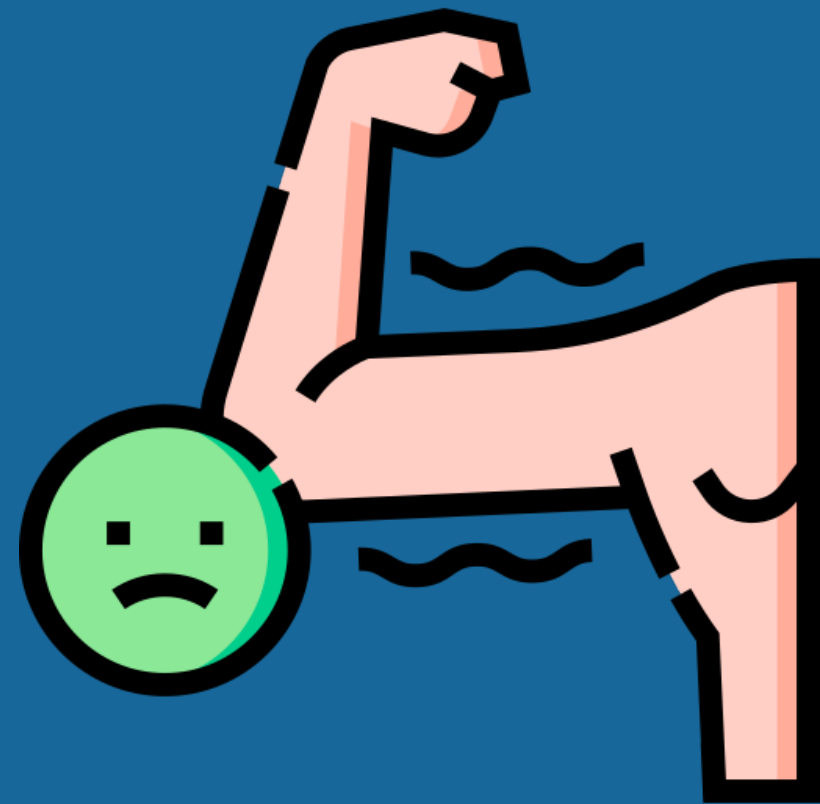

STRONGER TEST SET

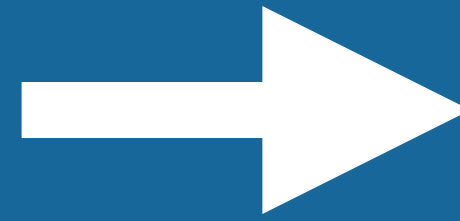

MUTANTS



ORIGINALS

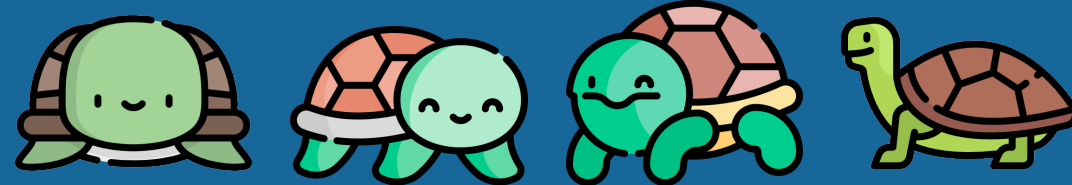

MUTANTS



ORIGINALS

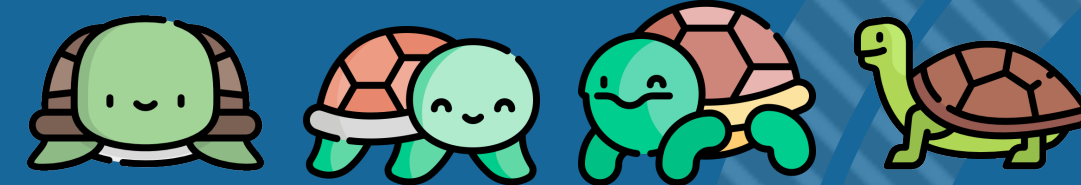

GOAL

Original Program



Original Test Set



Mutation Operator

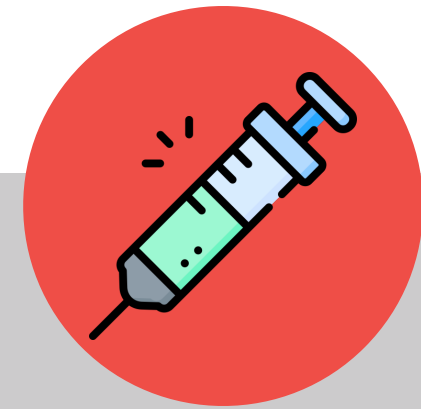

DeepCrime



Original Models

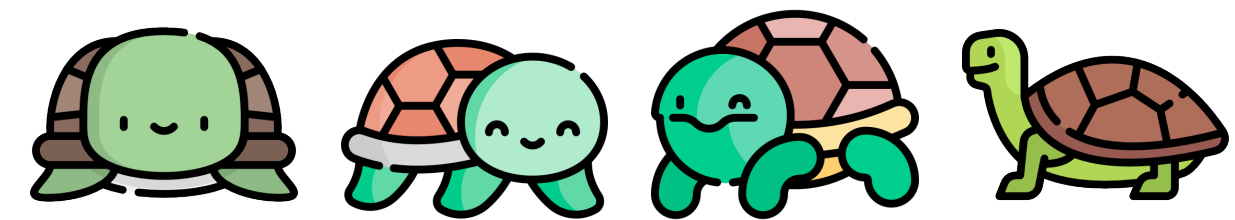

Mutant Models



Remove portion of training data

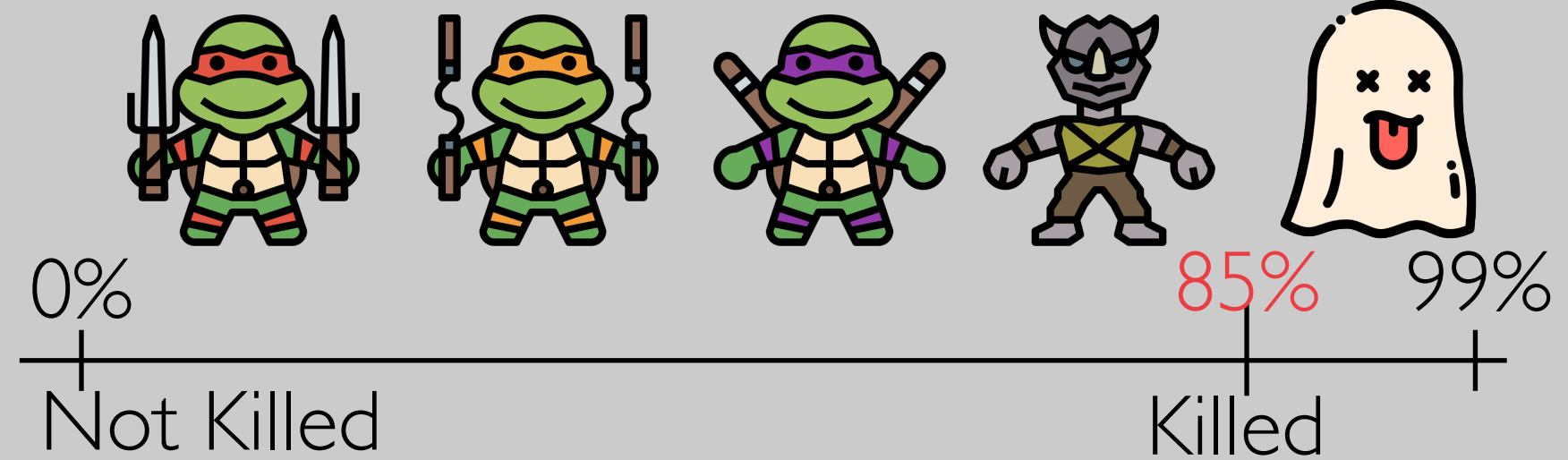

GOAL

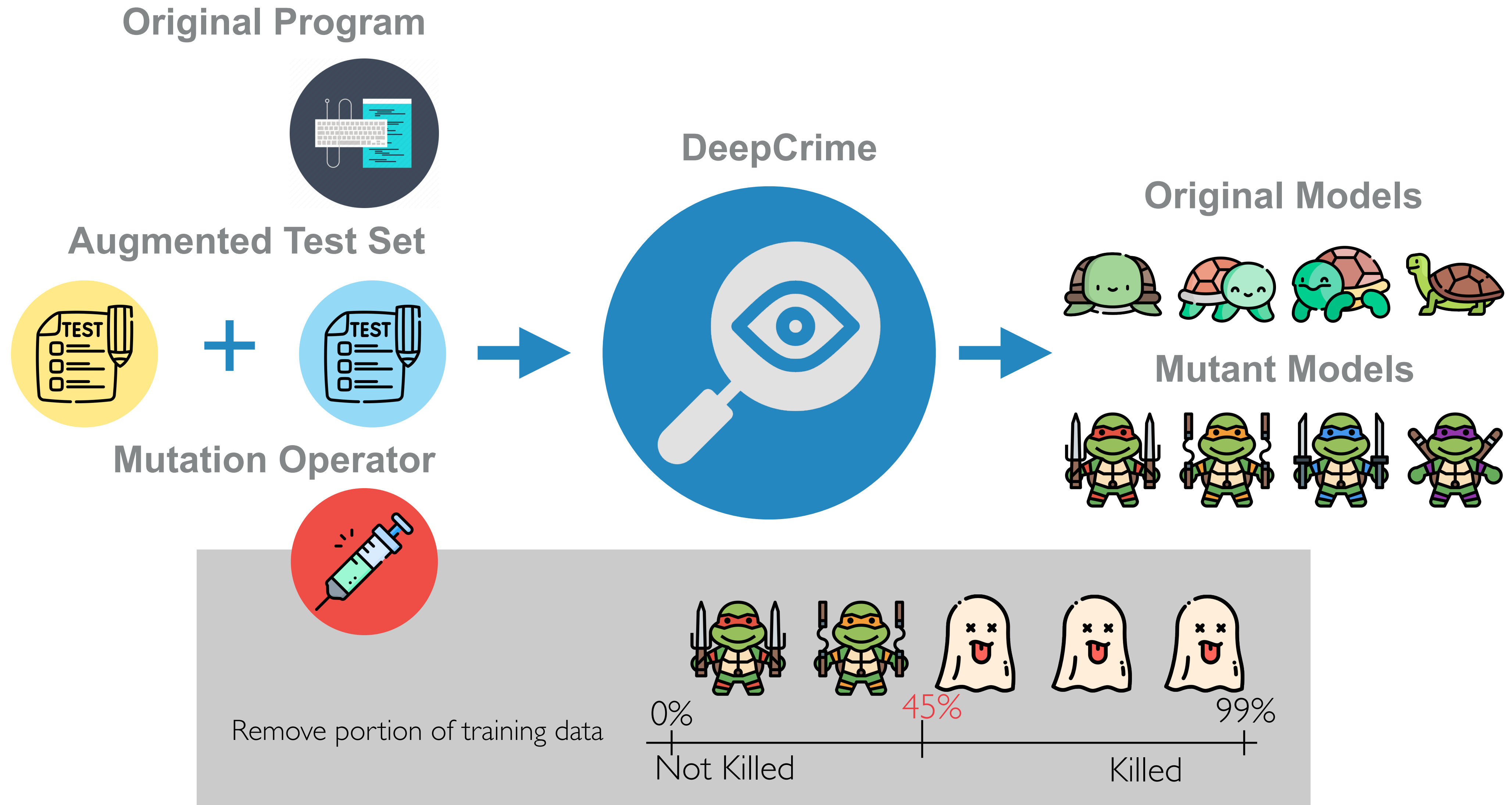

DEEPMETIS

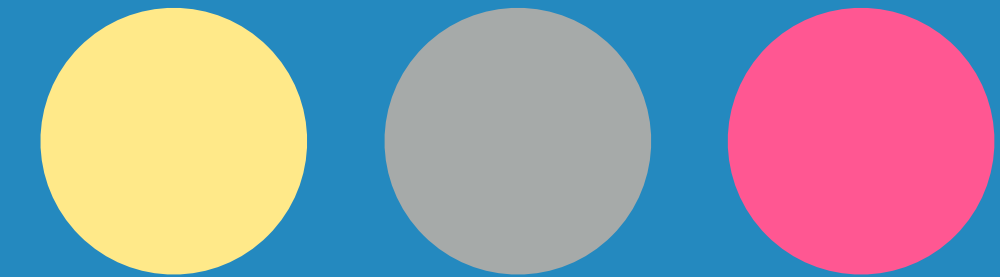
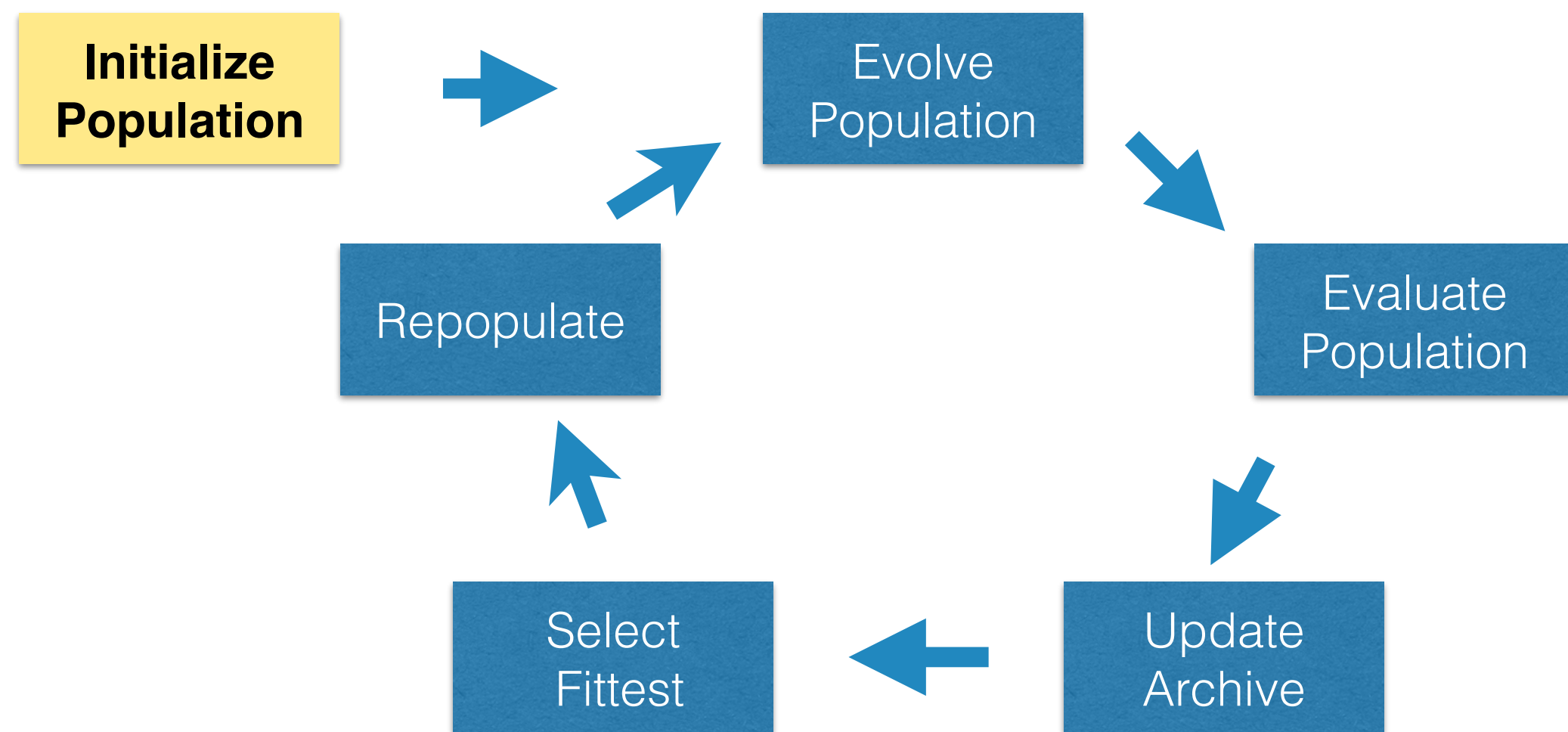

DEEPMETIS

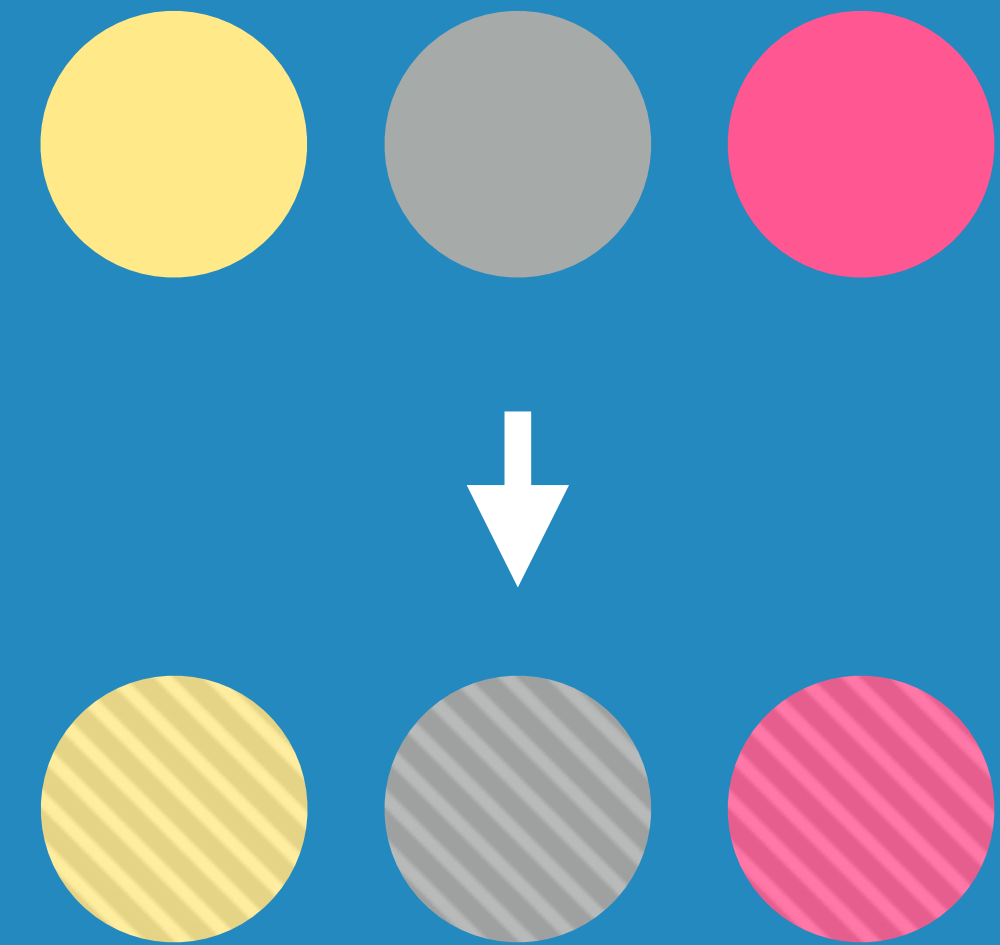
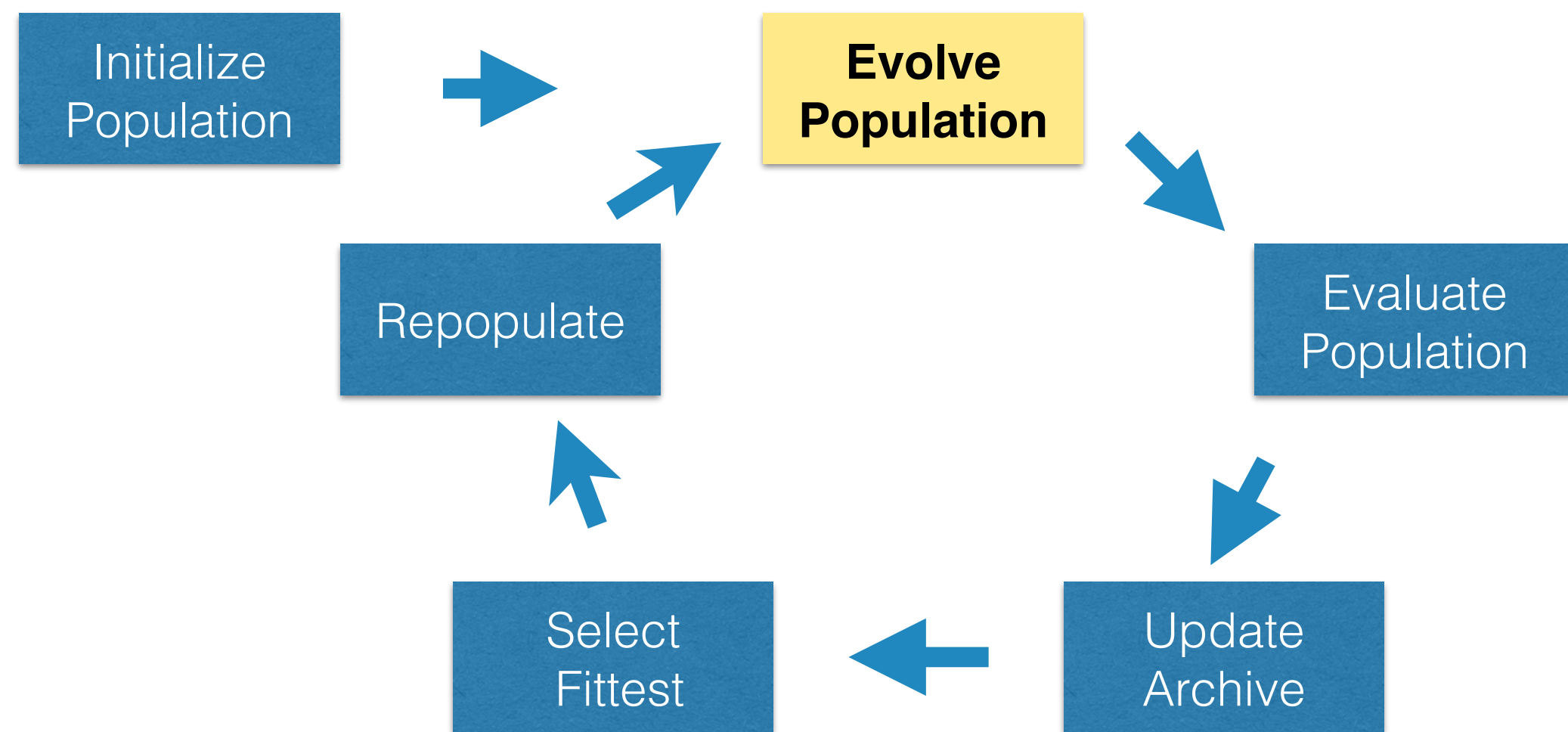

DEEPMETIS

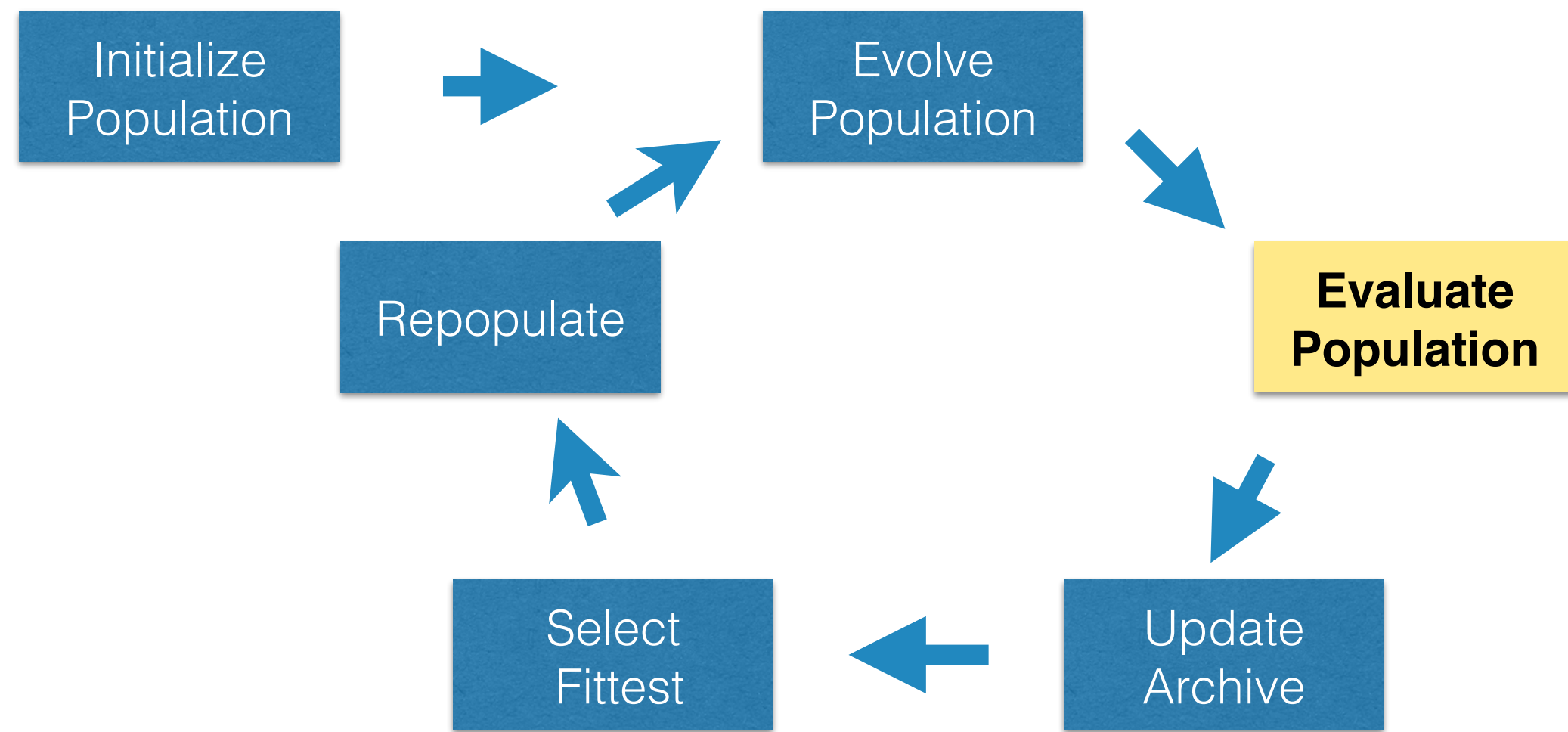

DEEPMETIS

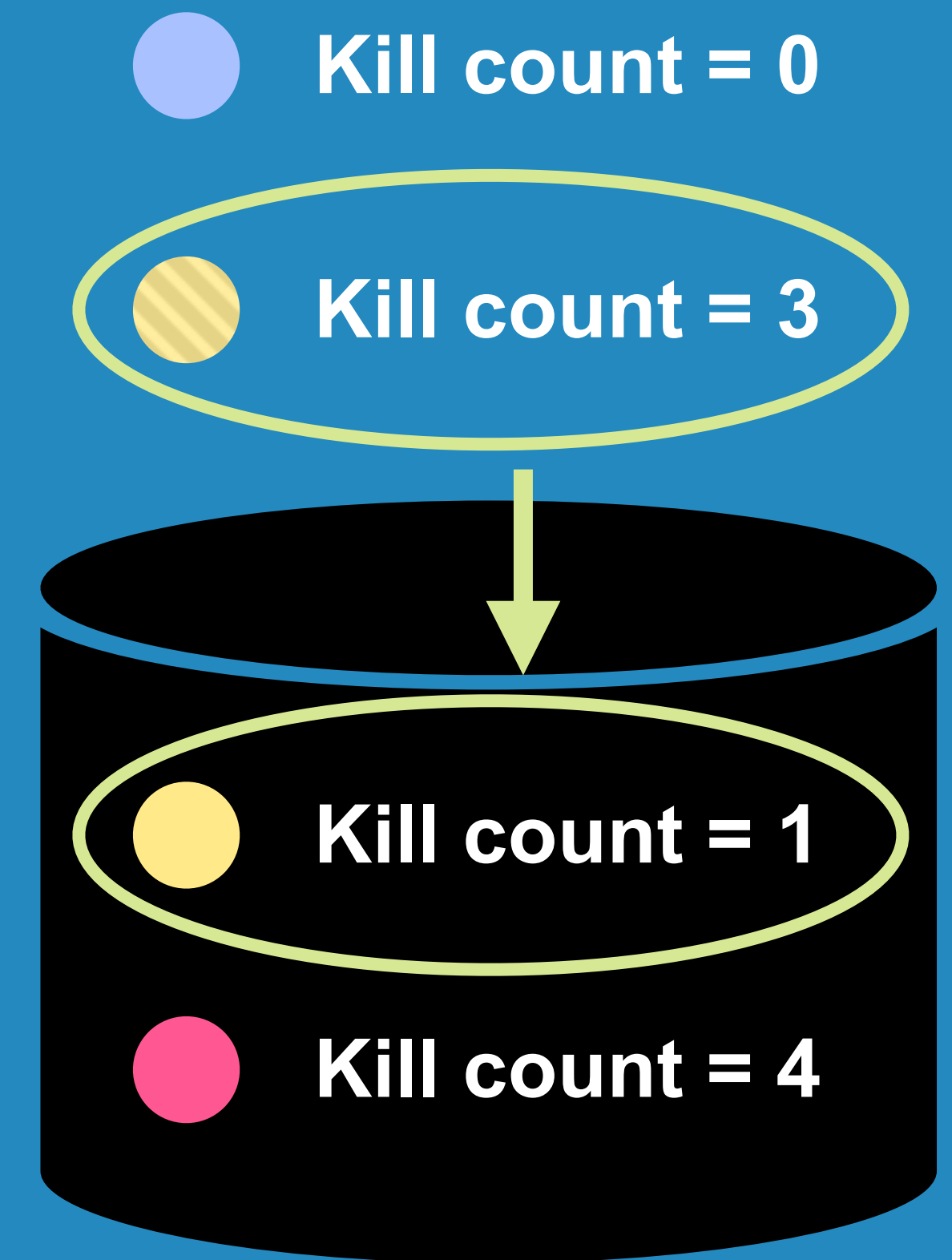
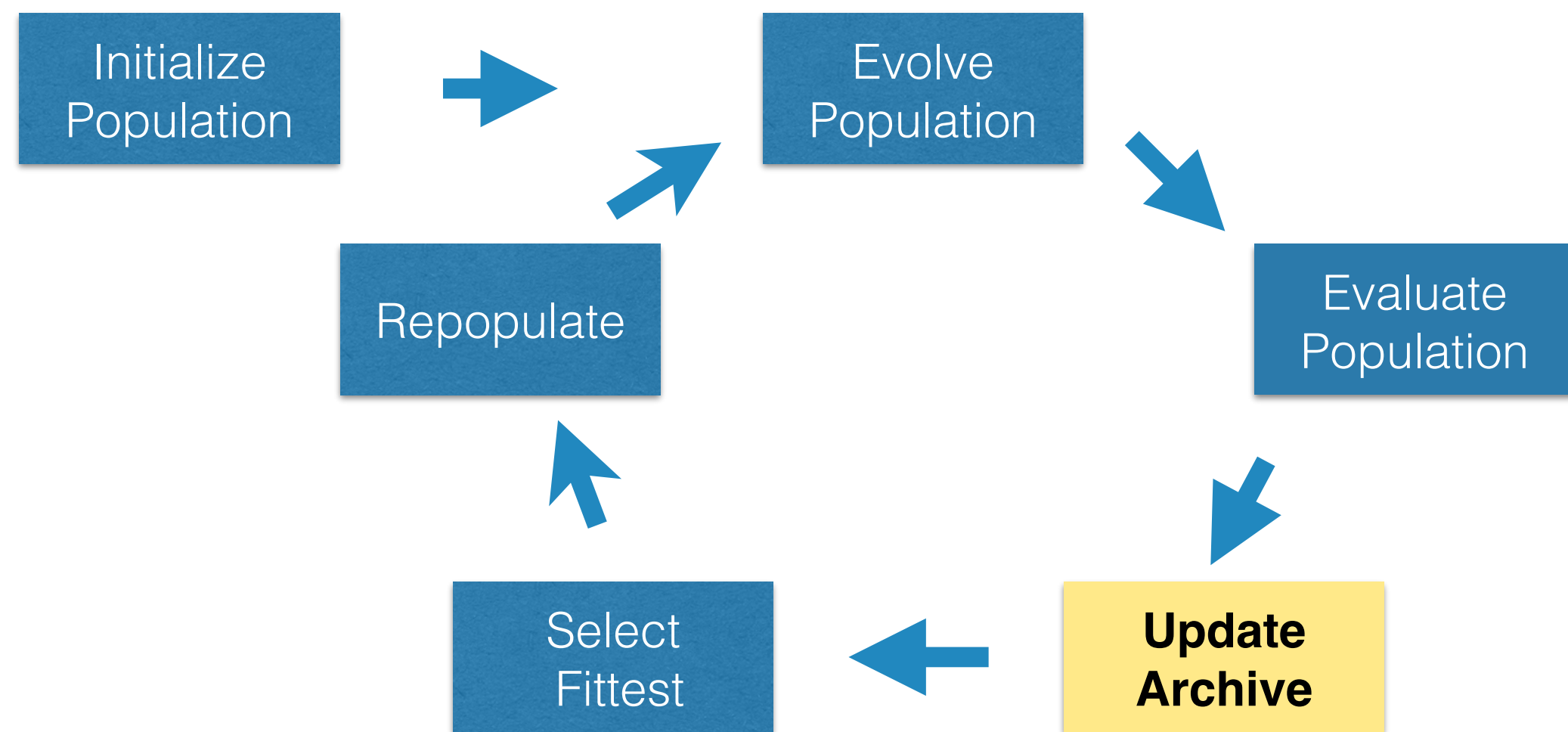

DEEPMETIS

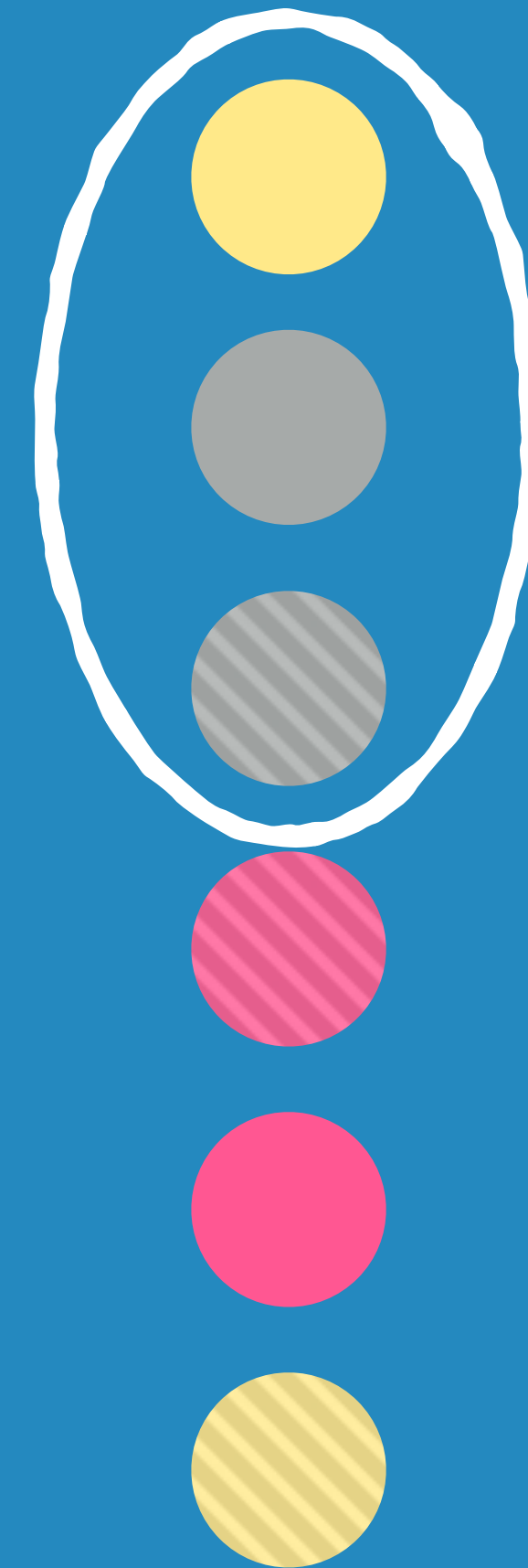
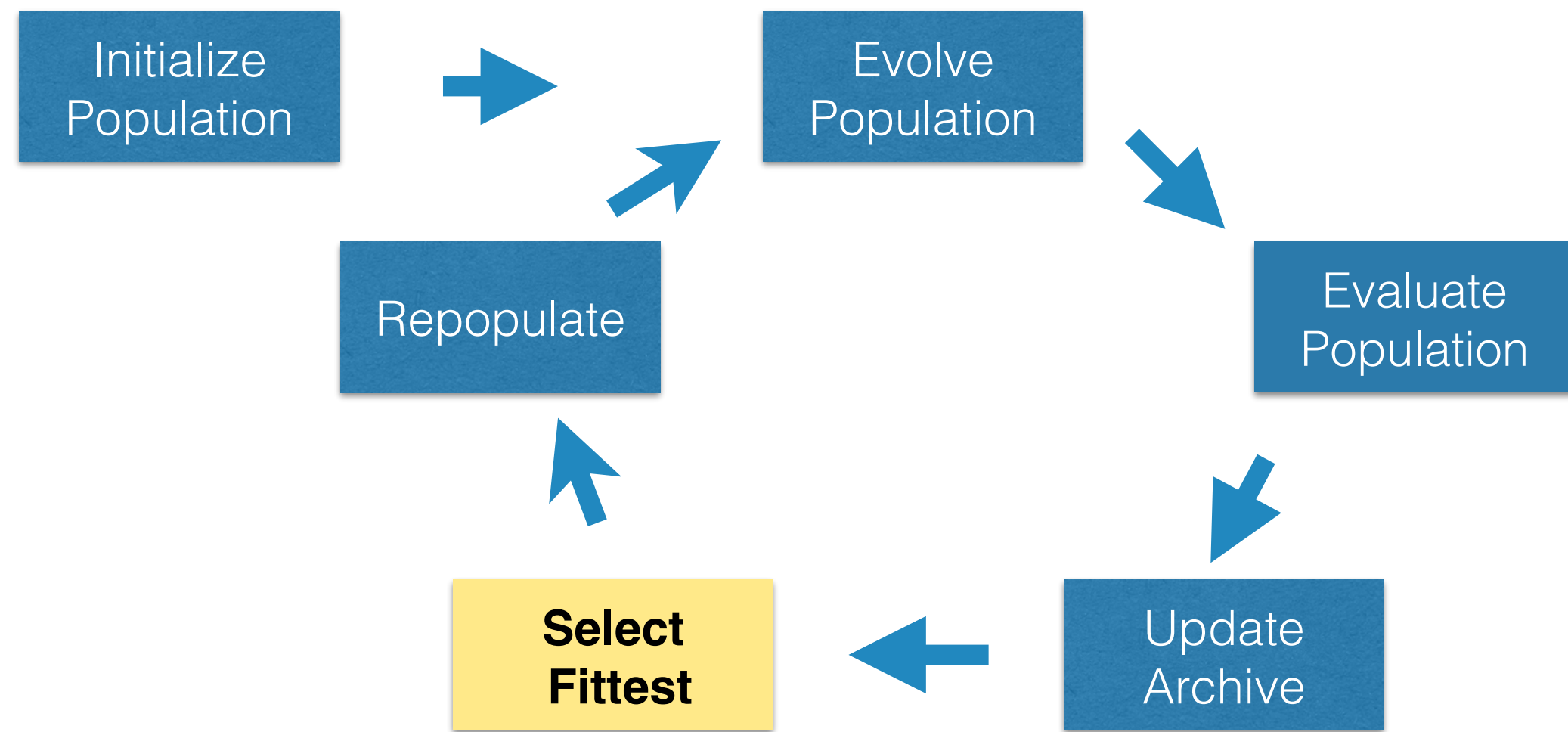

Fitness 1:

Killing ability

Fitness 2:

Diversity from archive

DEEPMETIS

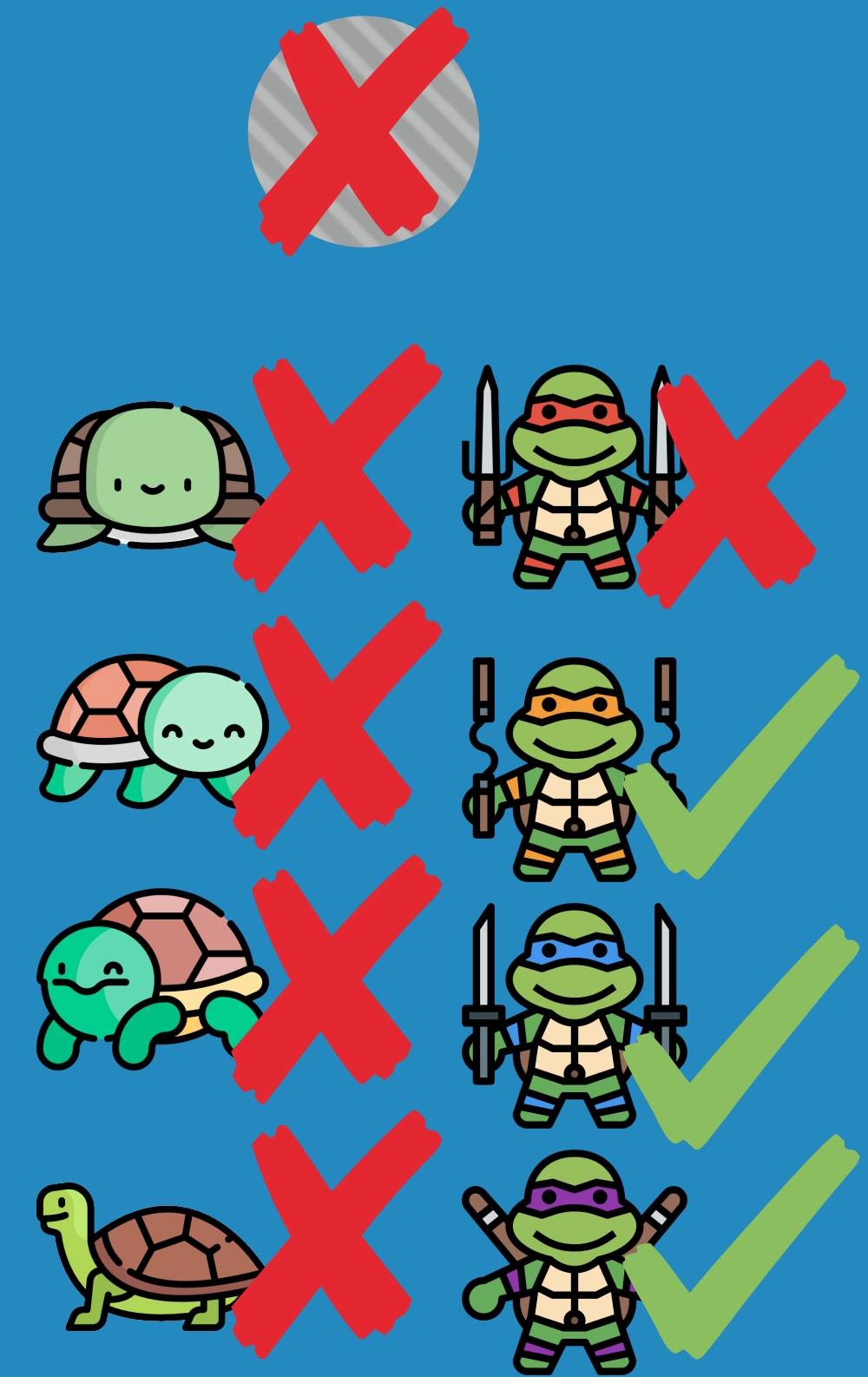
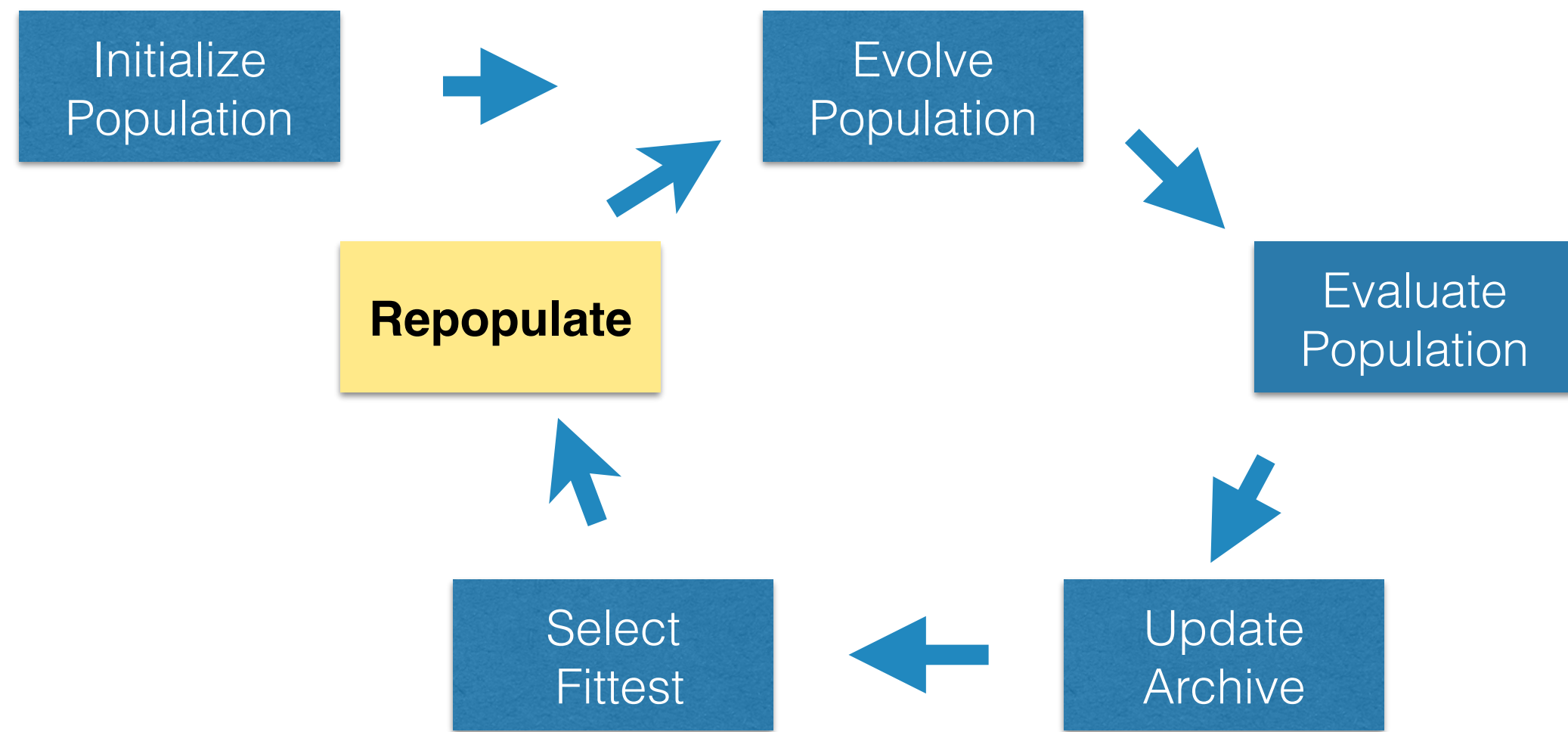

EXPERIMENTAL EVALUATION

MNIST



UNITYEYES

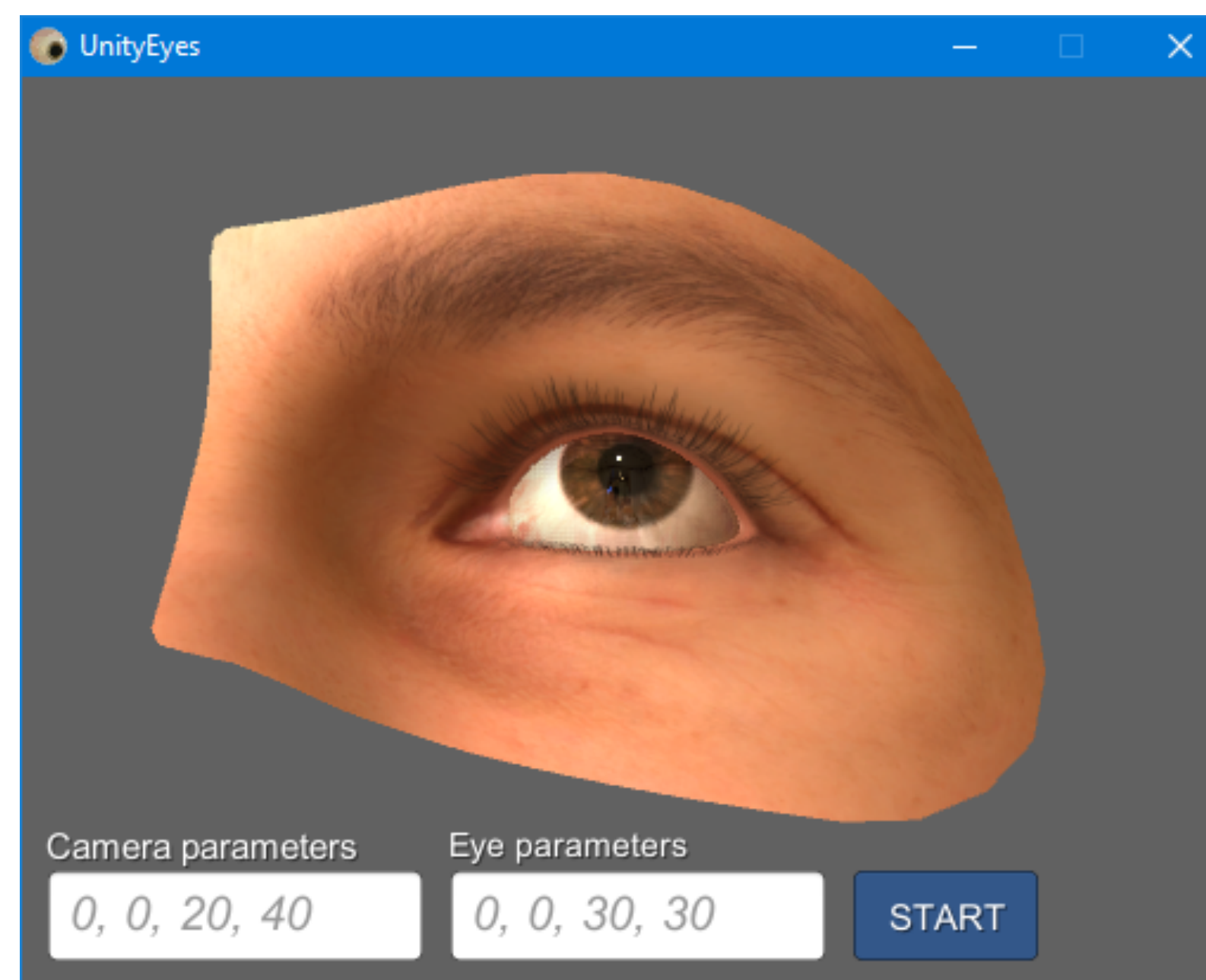

EFFECTIVENESS

GENERATION OF
MUTANT KILLING
INPUTS

COMPARISON
WITH STATE
OF THE ART

EFFECTIVENESS

Mutation Killing (%)

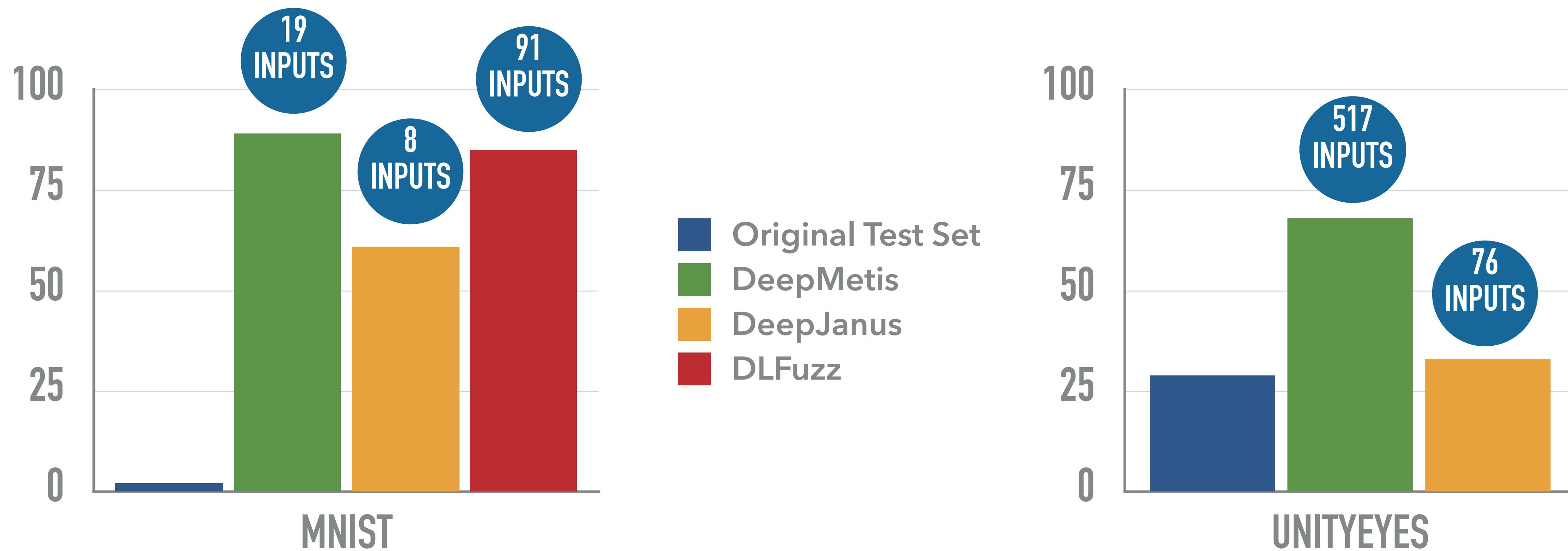

FAULT DETECTION

DEEPMETIS

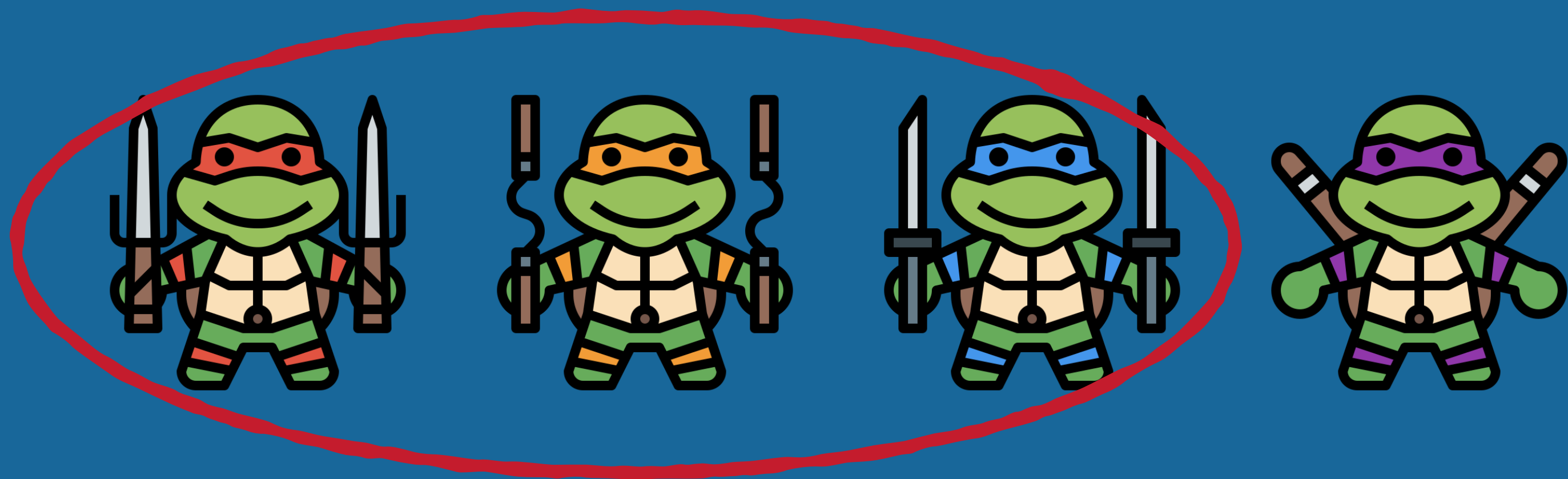

FAULT DETECTION

DEEPMETIS

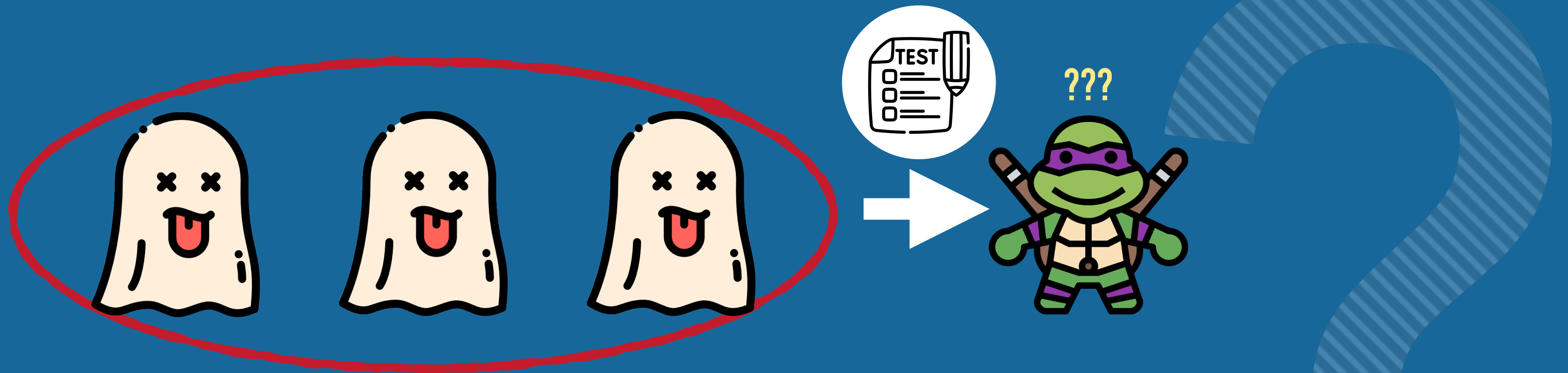

FAULT DETECTION

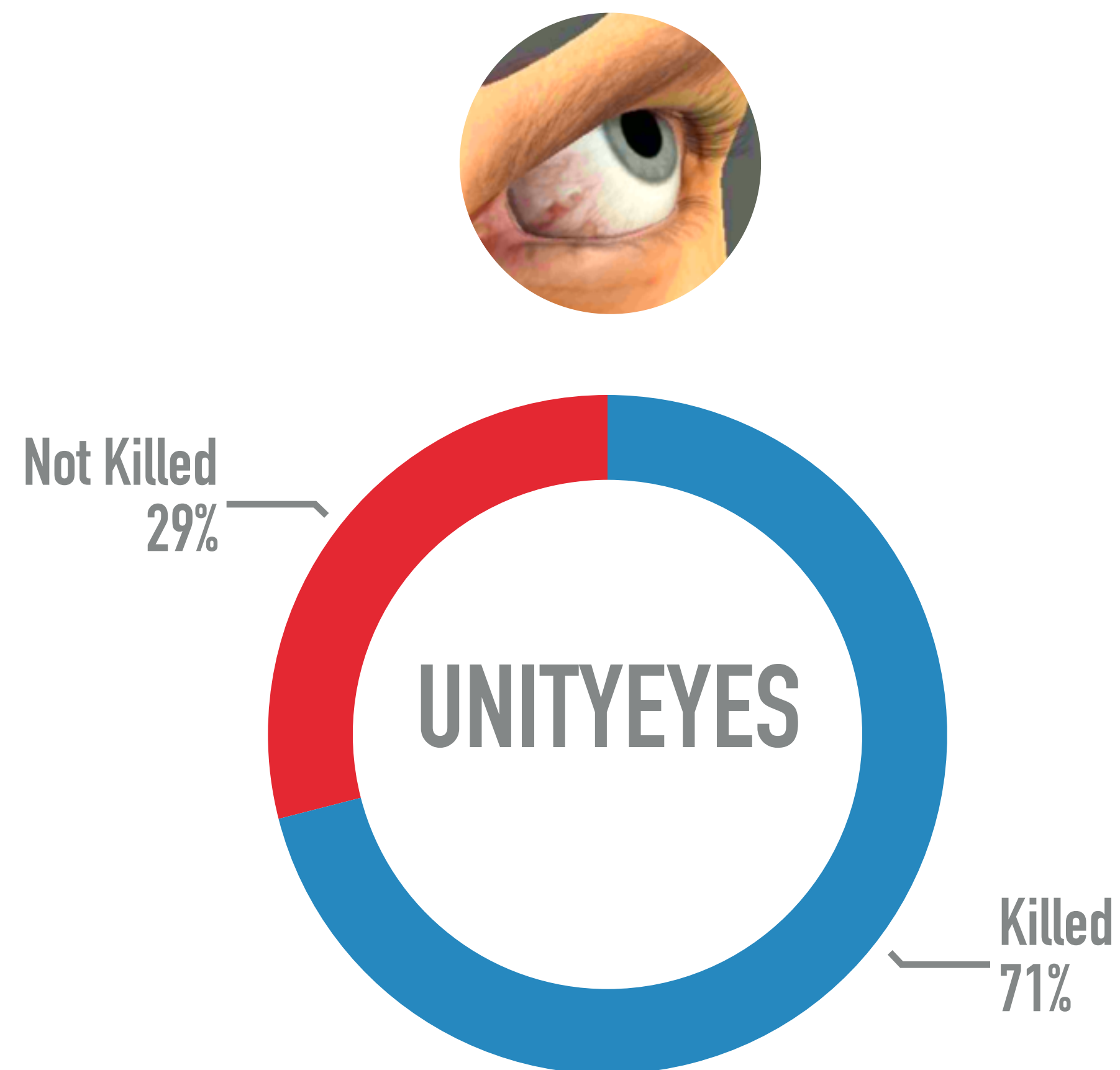
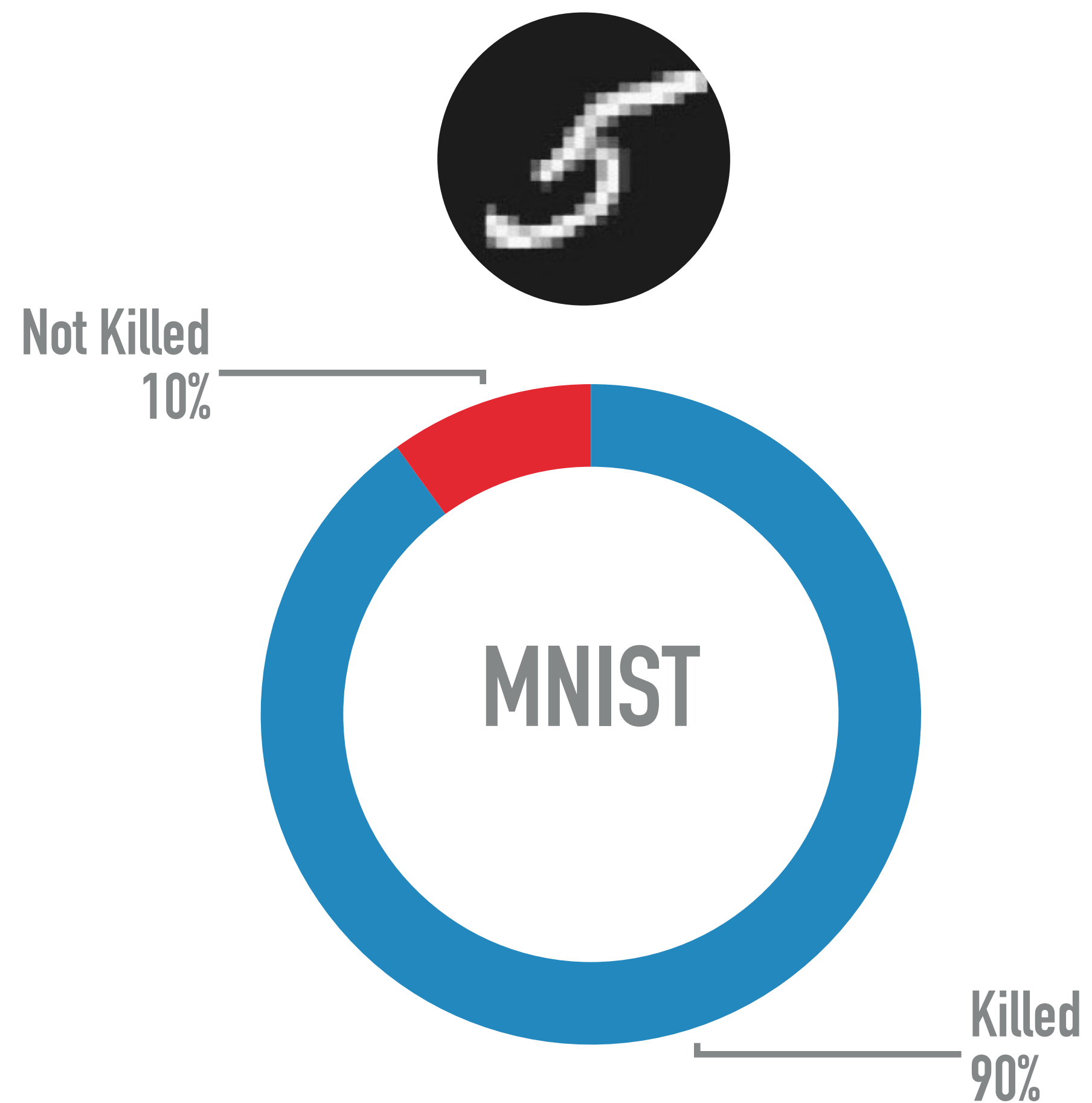

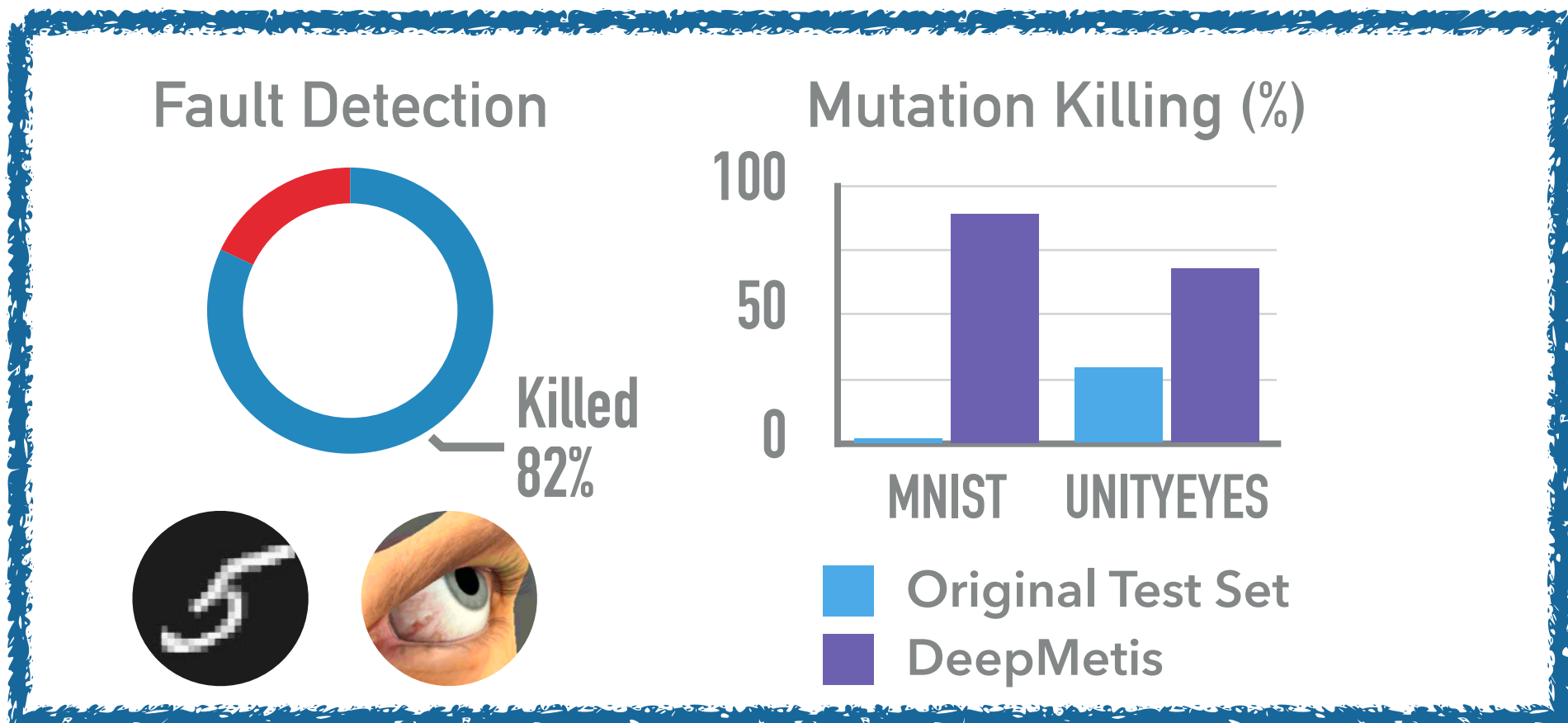
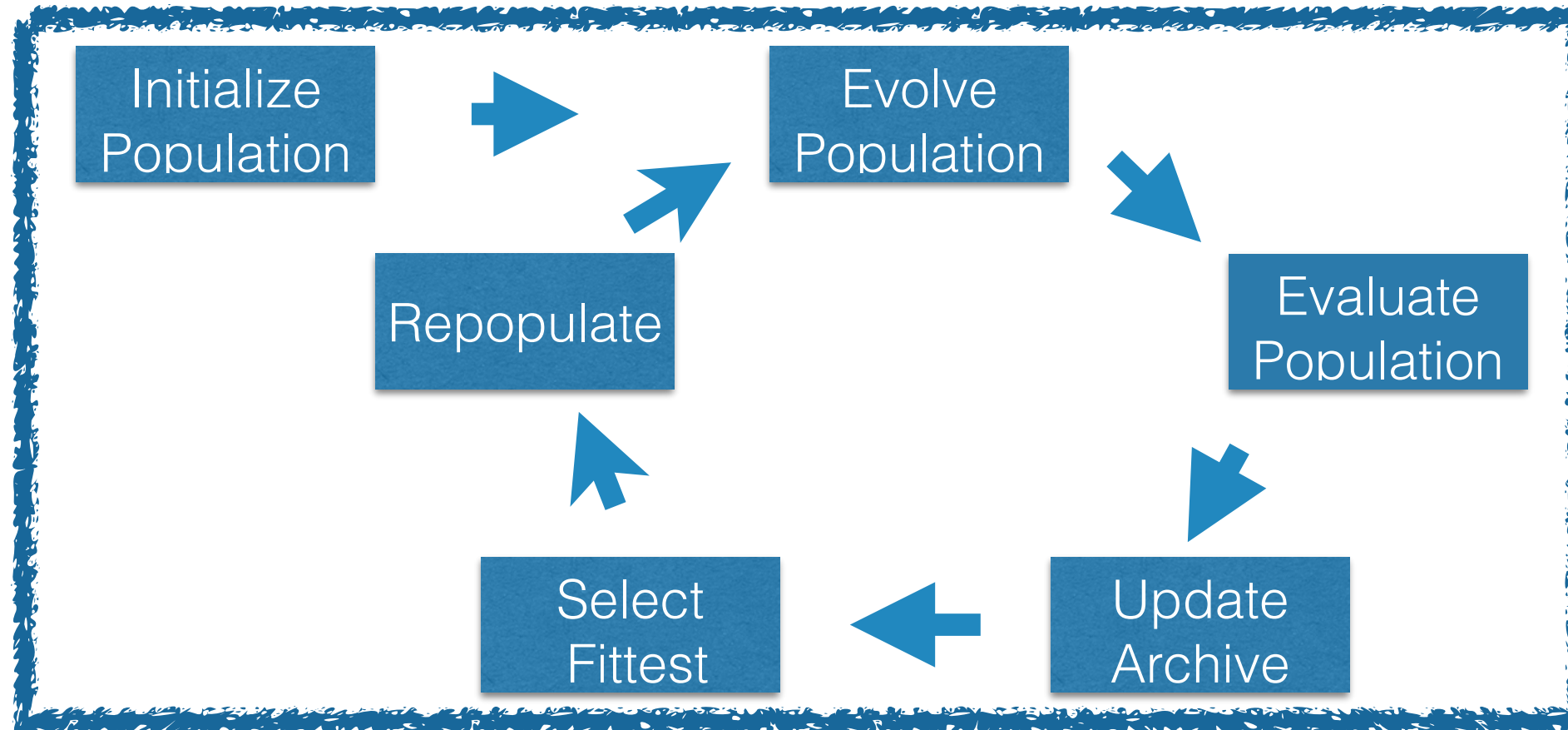
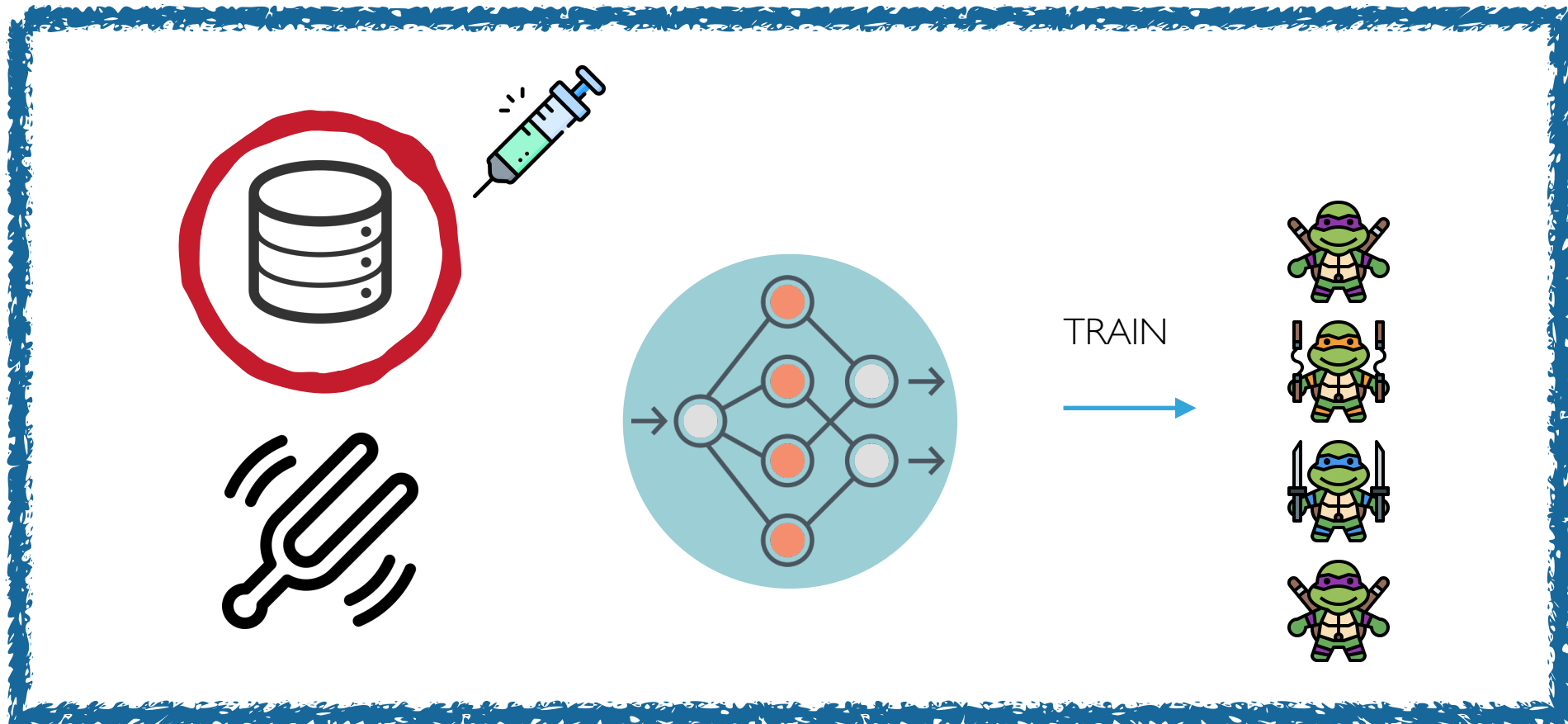

Artifact

Available Reusable